



IS : 4038



← Quality Assurance

MINOTI

FOOT VALVE WITH STRAINER

SIZE-25 m. m. to 150 m. m.



FOOT VALVE (Swing Type)

WITH STRAINER. As Per IS : 4038

SIZE : 25 m.m. to 150 m.m.

CONSTRUCTION

'MINOTI' Brand Foot Valve is generally placed at the lower end of the Suction Pipe to prevent the Suction Pipe from emptying while the pump at rest and manufactured the Valves of swing type with flanged or screwed ends

SPECIFICATION

Foot Valves manufacture as per IS : 4038 and other International Standard for swing type.

NOMINAL SIZE

From 25 mm to 150 mm

NAME OF PARTS

Body or Housing, Seat
Discs and Disc Plates

Strainers

Hinge Pins

Disc Faces

Flange Jointing
Materials

Bolts & Nuts

MATERIAL SPECIFICATION

Cast Iron	: IS : 210 Gr. FG 150
Cast Iron	: IS : 210 Gr. FG 150
Galvanised	
Steel	: IS : 277 Class 3
Brass	: IS : 319 & IS : 320
Leather	: IS : 581
Leaded tin	
Bronze	: IS : 318 Gr. LTB 2
Natural	
Rubber	: IS : 5192 Gr. 1 Type B
Seat	
Rubber	: IS : 638 Type A or B
Synthetic	
Rubber	: IS : 7450 Gr. 1
Seat	
Rubber	: IS : 638 Type A or B
Compressed	
Asbestos	: IS : 2712 G and C
Steel	: IS : 1367, CL4, 4. 6

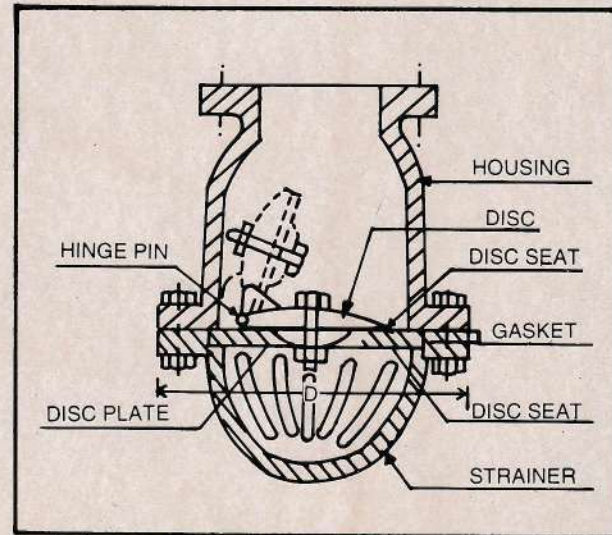

Test Pressure

Size	Body	Seat
from 25 mm to 150 mm.	6 KGF/CM ²	2 KGF/CM ²

MAXIMUM DIAMETERS OF ENDS OF VALVES

Size mm.	25	32	40	50	65	80	100	125	150
Diameter of ends (D) max.	120	140	150	160	220	240	290	340	380



MINOTI ENGINEERING WORKS

32, BUXARAH ROAD, HOWRAH-711306
WEST BENGAL, INDIA

Cable : 'MINOTICO' Santragchi

Office 68-6054 686088

PHONE : Resi: 68-5557

FAX : 033-686054